

Intel® x IEI TANK AIoT Developer Kit New

Features

- 6th/7th Gen Intel® Core™/Xeon® processor platform with Intel® Q170/C236 chipset and DDR4 memory
- Dual independent display with high resolution support
- Rich high-speed I/O interfaces on one side for easy installation
- On-board internal power connector for providing power to add-on cards
- Great flexibility for hardware expansion
- Pre-installed Open Visual Inference & Neural Network Optimization (OpenVINO™) toolkit
- Pre-installed Ubuntu 16.04 LTS



Deep learning and inference

Deep learning is part of the machine learning method. It allows computational models that are composed of multiple processing layers to learn representations of data with multiple levels of abstraction. Deep neural network and recurrent neural network architectures have been used in applications such as object recognition, object detection, feature segmentation, text-to-speech, speech-to-text, translation, etc. In some cases the performance of deep learning algorithms can be even more accurate than human judgement.

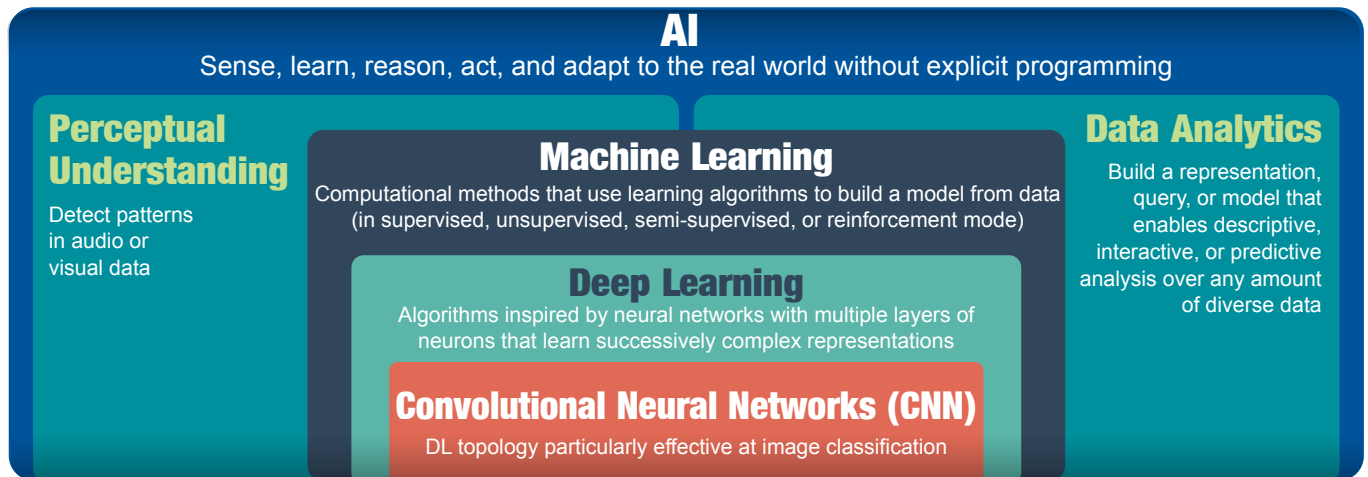

In the past, machine learning required researchers and domain experts knowledge to design filters that extracted the raw data into feature vectors. However, with the contributions of deep learning accelerators and algorithms, trained models can be applied to the raw data, which could be utilized to recognize new input data in inference.

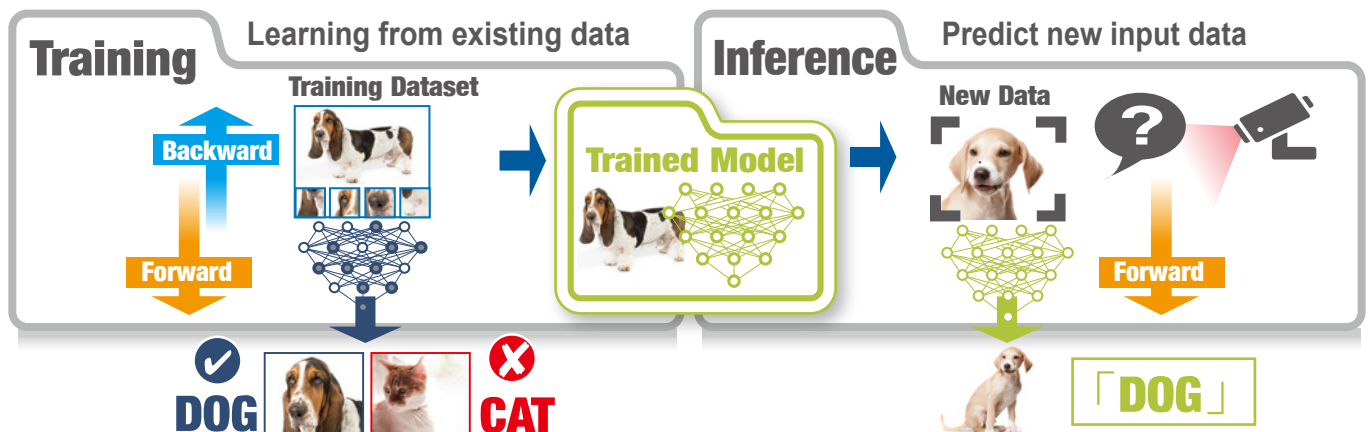

OpenVINO™ toolkit

OpenVINO™ is based on convolutional neural networks (CNN), the toolkit extends workloads across Intel® hardware and maximizes performance.

It can optimize pre-trained deep learning models such as Caffe, MXNET, and Tensorflow. The tool suite includes more than 20 pre-trained models, and supports 100+ public and custom models (includes Caffe*, MXNet, TensorFlow*, ONNX*, Kaldi*) for easier deployments across Intel® silicon products (CPU, GPU/Intel® Processor Graphics, FPGA, VPU).

- Intel® Deep Learning Deployment Toolkit
 - Model Optimizer
 - Inference Engine
- Optimized computer vision libraries
- Intel® Media SDK
- OpenCL™ graphics drivers and runtimes.

(OpenCL™ is the trademark of Apple Inc. used by permission by Khronos)
- Current Supported Topologies: AlexNet, GoogleNet, Tiny Yolo, LeNet, SqueezeNet, VGG16, ResNet

(more variants are coming soon)

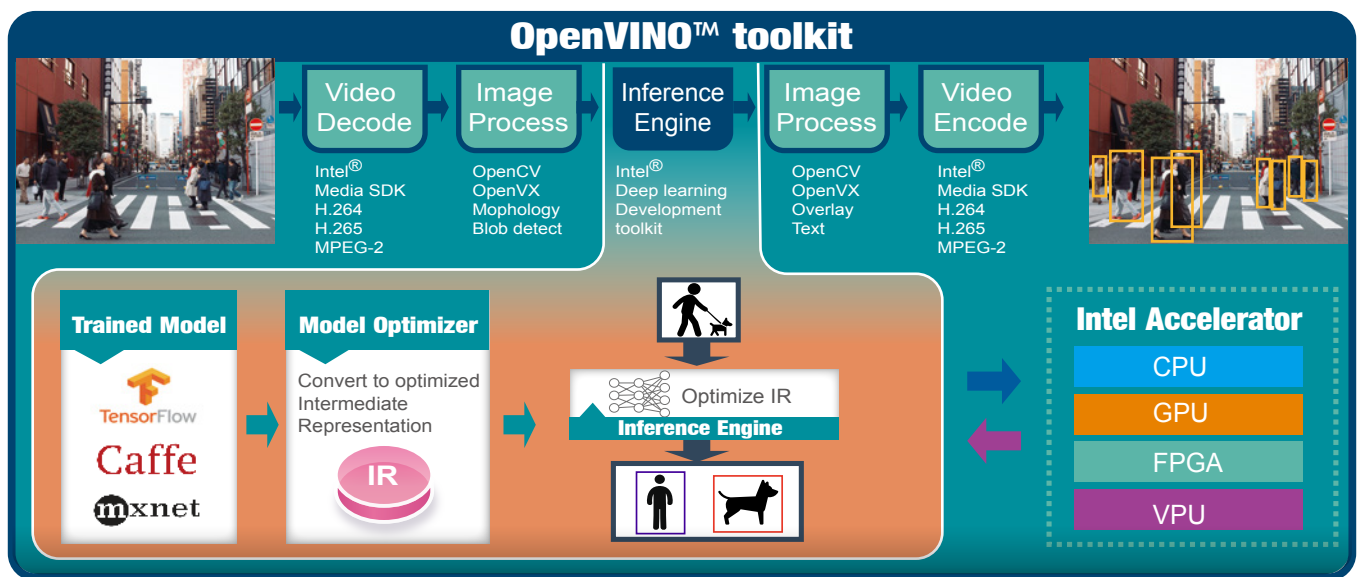

Smart Choice for Inference System With AI

Artificial Intelligence, AI, is changing our lives from the past to the future. It enables machine learning by using a variety of training models to simulate and infer the status or appearance of objects. For example, the inference system with the video analysis model can perform face and vehicle license plate analysis for safety and security purposes.

The TANK AIoT Dev. Kit features rich I/O and dual PCIe slots (x16) to support add-ons like the Acceleration cards (Mustang-F100-A10 & Mustang-V100-MX8) or the PoE (IPCIIE-4POE) to enhance performance and function for various applications.



Machine Vision

Vision Analytics on the factory floor adds intelligence to factories design and process. Today's technologies automate the collection, storage, retrieval, and decision making across multiple factories and factory sub-systems at the edge.



Numerous Vehicle License Plate Analysis

Efficient road tolling and parking reduces fraud related to non-payment, makes charging effective, and reduces required manpower to process. Vehicle license plate analysis can be deployed on highways for electronic toll collection, and can be implemented as a method of cataloguing the movement of traffic as well as provide enhanced security by establishing data on suspicious vehicles in a more efficient way.



Numerous Face Recognition

Face analysis with AI has explosive growth in various domains. It not only infers human features like gender, age and facial expression, but also identifies identity, which can greatly reduce labor costs and provide services via big data in retail, finance and medicine.

Specifications

Model Name		TANK AIoT Dev. Kit
Chassis	Color	Black C + Silver
	Dimensions (WxHxD) (mm)	121.5 x 255.2 x 205 mm (4.7" x 10" x 8")
	System Fan	Fan
	Chassis Construction	Extruded aluminum alloys
	Weight (Net/Gross)	4.2 kg (9.26 lbs)/ 6.3 kg (13.89 lbs)
Motherboard	CPU	Intel® Xeon® E3-1268LV5 2.4GHz (up to 3.4 GHz, Quad Core, TDP 35W) Intel® Core™ i7-7700T 2.9GHz (up to 3.8 GHz, Quad Core, TDP 35W) Intel® Core™ i5-7500T 2.7GHz (up to 3.3 GHz, Quad Core, TDP 35W) Intel® Core™ i7-6700TE 2.4 GHz (up to 3.4GHz, quad-core, TDP=35W) Intel® Core™ i5-6500TE 2.3 GHz (up to 3.3GHz, quad-core, TDP=35W)
	Chipset	Intel® Q170/C236 with Xeon® E3 only
	System Memory	2 x 260-pin DDR4 SO-DIMM, 8 GB pre-installed (for i5/i5KBL/i7 sku) 16 GB pre-installed (for i7KBL sku) 32 GB pre-installed (for E3 sku)
Storage	Hard Drive	2 x 2.5" SATA 6Gb/s HDD/SSD bay, RAID 0/1 support (1x 2.5" 1TB HDD pre-installed)
I/O Interfaces	USB 3.0	4
	USB 2.0	4
	Ethernet	2 x RJ-45 LAN1: Intel® I219LM PCIe controller with Intel® vPro™ support LAN2 (iRIS): Intel® I210 PCIe controller
	COM Port	4 x RS-232 (2 x RJ-45, 2 x DB-9 w/2.5KV isolation protection) 2 x RS-232/422/485 (DB-9)
	Digital I/O	8-bit digital I/O, 4-bit input / 4-bit output
	Display	1 x VGA 1 x HDMI/DP 1 x iDP (optional)
	Resolution	VGA: Up to 1920 x 1200@60Hz HDMI/DP: Up to 3840x2160@30Hz / 4096x2304@60Hz
	Audio	1 x Line-out, 1 x Mic-in
	TPM	1x Infineon TPM 2.0 Module
	Expansions	Backplane
PCIe Mini		1 x Half-size PCIe Mini slot 1 x Full-size PCIe Mini slot (supports mSATA, colay with SATA)
Power	Power Input	DC Jack: 9 V~36 V DC Terminal Block: 9 V~36 V DC
	Power Consumption	19 V@3.68 A (Intel® Core™ i7-6700TE with 8 GB memory)
	Internal Power output	5V@3A or 12V@3A
Reliability	Mounting	Wall mount
	Operating Temperature	Xeon® E3 -20°C ~ 60°C with air flow (SSD), 10% ~ 95%, non-condensing i7-7700T -20°C ~ 35°C with air flow (SSD), 10% ~ 95%, non-condensing i5-7500T -20°C ~ 45°C with air flow (SSD), 10% ~ 95%, non-condensing i7-6700TE -20°C ~ 45°C with air flow (SSD), 10% ~ 95%, non-condensing i5-6500TE -20°C ~ 60°C with air flow (SSD), 10% ~ 95%, non-condensing
	Operating Vibration	MIL-STD-810G 514.6 C-1 (with SSD)
	Safety/EMC	CE/FCC/RoHS
OS	Supported OS	Win10/Linux Ubuntu 16.04 LTS

Fully Integrated I/O

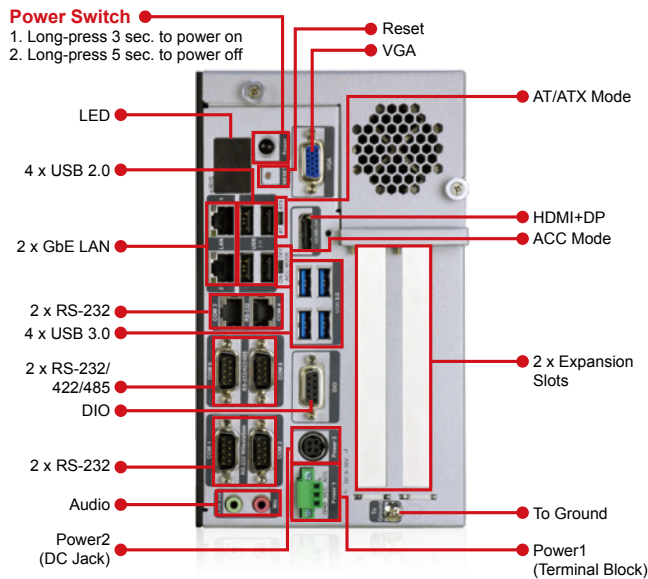

Dimensions (Unit: mm)

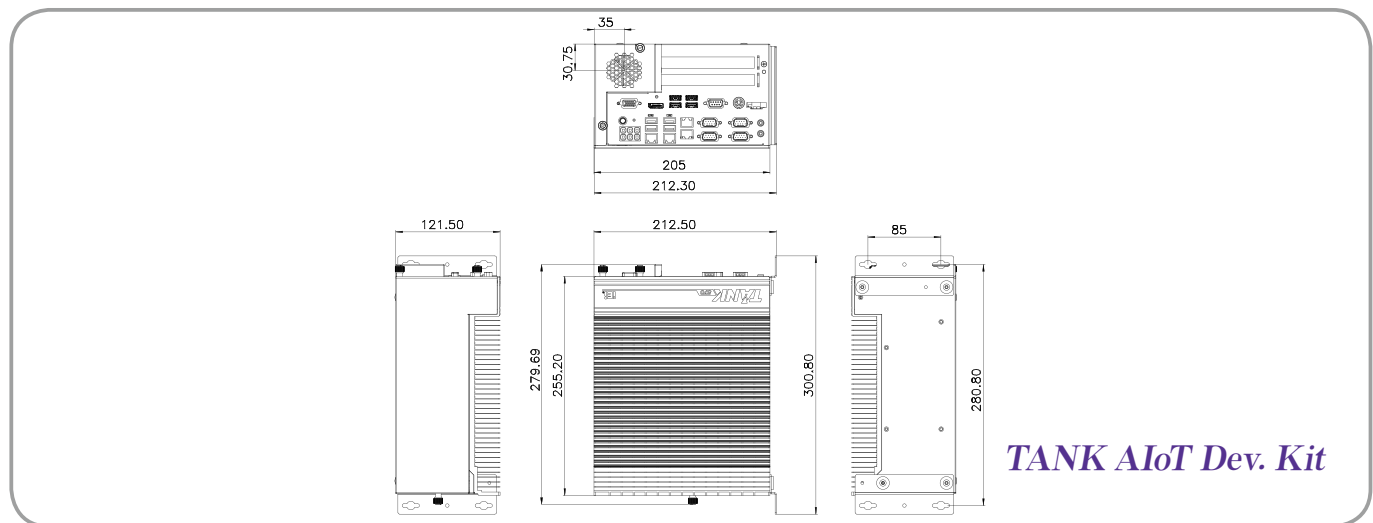

TANK AIoT Dev. Kit

Ordering Information

Part No.	Description
TANK-870AI-E3/32G/2A-R11	Ruggedized embedded system with Intel® Xeon® E3-1268LV5 2.4GHz, (up to 3.4 GHz, Quad Core, TDP 35W), 32 GB DDR4 pre-installed memory, 2 x PCIe by 8 expansion, 2.5" 1TB HDD , TPM 2.0 , 9~36V DC, 120W AC DC power adaptor , RoHS
TANK-870AI-I7KBL/16G/2A-R11	Ruggedized embedded system with Intel® Core™ i7-7700T 2.9GHz, (up to 3.8 GHz, Quad Core, TDP 35W), 16 GB DDR4 pre-installed memory, 2 x PCIe by 8 expansion, 2.5" 1TB HDD , TPM 2.0 , 9~36V DC, 120W AC DC power adaptor , RoHS
TANK-870AI-I5KBL/8G/2A-R11	Ruggedized embedded system with Intel® Core™ i5-7500T 2.7GHz, (up to 3.3 GHz, Quad Core, TDP 35W), 8 GB DDR4 pre-installed memory, 2 x PCIe by 8 expansion, 2.5" 1TB HDD , TPM 2.0 , 9~36V DC, 120W AC DC power adaptor , RoHS
TANK-870AI-I7/8G/2A-R11	Ruggedized embedded system with Intel® Core™ i7-6700TE 2.4GHz, (up to 3.4 GHz, Quad Core, TDP 35W), 8 GB DDR4 pre-installed memory, 2 x PCIe by 8 expansion, 2.5" 1TB HDD , TPM 2.0 , 9~36V DC, 120W AC DC power adaptor , RoHS
TANK-870AI-I5/8G/2A-R11	Ruggedized embedded system with Intel® Core™ i5-6500TE 2.3GHz, (up to 3.3 GHz, Quad Core, TDP 35W), 8 GB DDR4 pre-installed memory, 2 x PCIe by 8 expansion, 2.5" 1TB HDD , TPM 2.0 , 9~36V DC, 120W AC DC power adaptor , RoHS

AI Accelerator Card Options

Part No.	Description
Mustang-F100-A10-R10	PCIe FPGA Highest Performance Accelerator Card with Arria 10 1150GX support DDR4 2400Hz 8GB, PCIe Gen3 x8 interface, RoHS
Mustang-V100-MX8-R10	Computing Accelerator Card with 8 x Movidius Myriad X MA2485 VPU, PCIe Gen2 x4 interface, RoHS

Peripheral Options

Part No.	Description
IPCIE-4POE-R10	PCI Express Power over ethernet card, 4-port 1000 Base(T), 802.3af compliant, RoHS
63040-010150-400-RS	Adapter Power; FSP; FSP150M-ABA; 9NA1505201; Active PFC; Vin: 90 ~ 264VAC; 150W; Dim: 85 x 170 x 42.5mm; Plug=6.5mm; Cable=1200mm; MEDICAL; Vout: 19VDC; Din 4Pin/lock; CCL; RoHS
72213100-5010000-000-RS	2.5" HDD;WD;Caviar Blue;WD10SPZX;SATA3.0(6Gb/s, 600MB/s);1TB;128MB;5400 RPM;NoAssign;NoAssign;;CCL;RoHS

Packing List

1 x Chassis Screw	1 x Mounting Bracket	1 x QSG	1 x 120W Adapter	1 x Power Cord
-------------------	----------------------	---------	------------------	----------------